

Geberit Montage ø 250

Pluvia-System

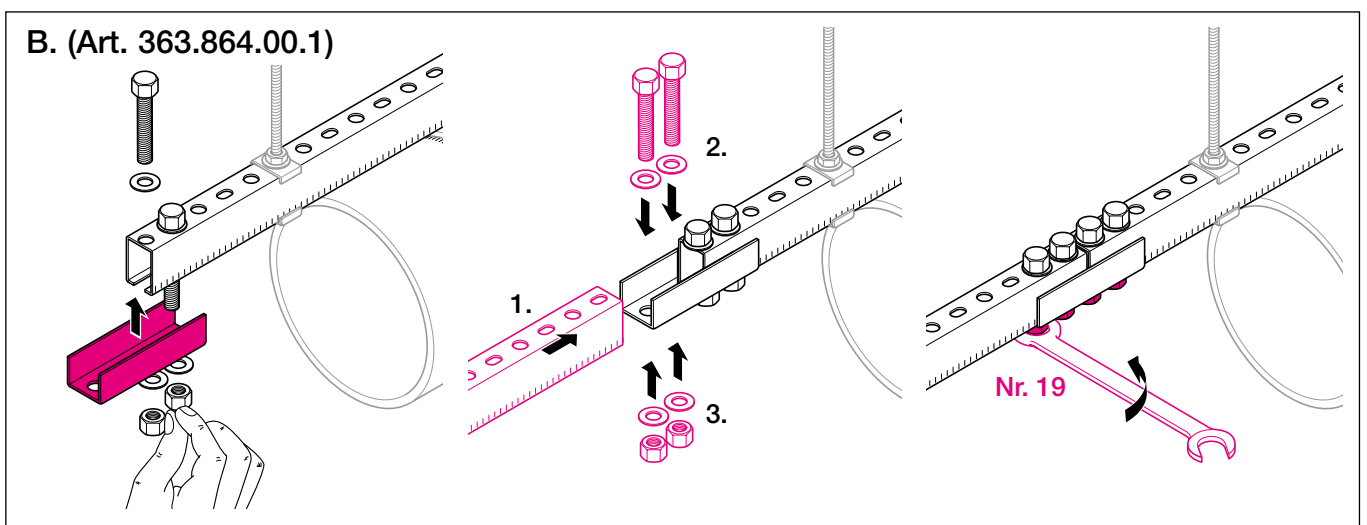
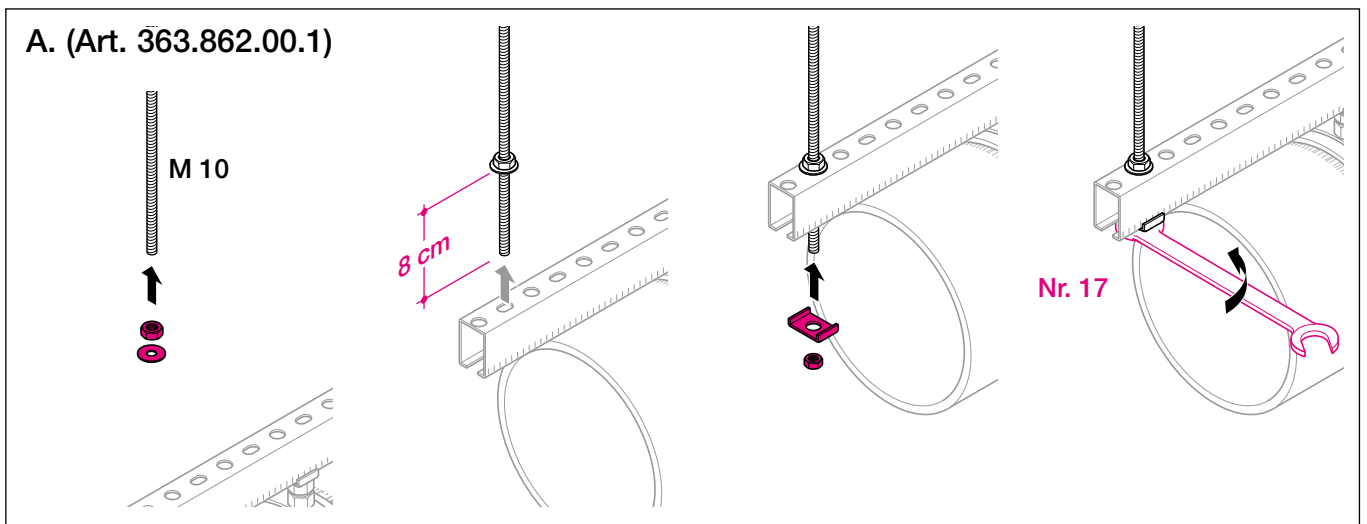
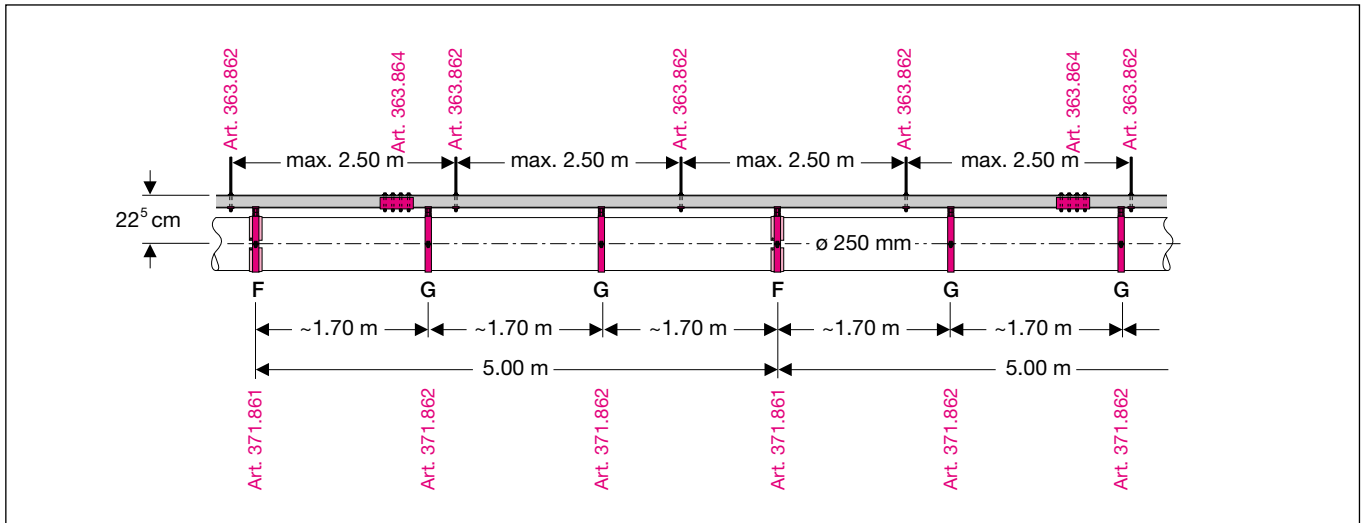

int. 8583-03

964.112.00.0

Geberit Montage 371.861



Anwendungs-Hinweise

Das Elektroschweissband wird zur Erstellung eines Fixpunktes bei starrer Montage verwendet. (Ist keine Rohrverbindung!) Der nötige Schweißdruck auf das saubere und trockene Geberit PE-Rohr wird durch anziehen der Rohrschelle erreicht.

Remarques pour l'utilisation

La bande électrique est utilisée comme point fixe lors d'un montage fixe. (N'est pas une pièce de raccordement!) La pression de soudure nécessaire, sur le tuyau PE Geberit propre et sec, est obtenue par le serrage du collier.

Indicazioni d'uso

La fascetta elettrica per punto fisso viene impiegata per avere un punto fisso nel montaggio rigido. (Non è un collegamento per tubi!) La pressione di saldatura necessaria sul tubo pulito ed asciutto Geberit PE viene raggiunta stringendo il bracciale.

Montage tips

De elektrolasband wordt voor het realiseren van een vast-beugelpunt bij starre montage toegepast. (Is geen buisverbindingselement!) De benodigde lasdruk op de schone en droge Geberit PE-buis wordt bereikt door het aandraaien van de beugel om mde lasband.

Application remarks

The electrowelding tape is used for anchor points in rigid installations. (It is not a connection piece!) The required welding pressure on the clean and dry Geberit PE-pipe surface will be obtained by tightening the pipe clamp.

C1.

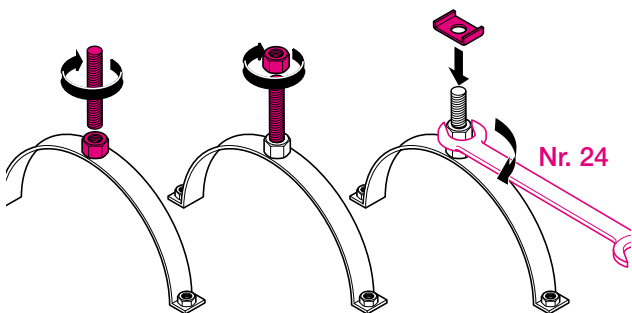

C2.

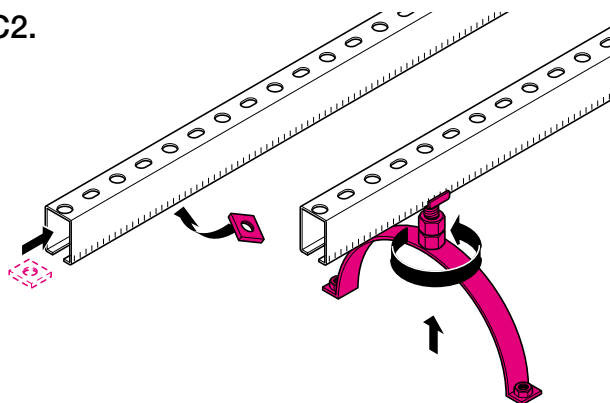

C3.

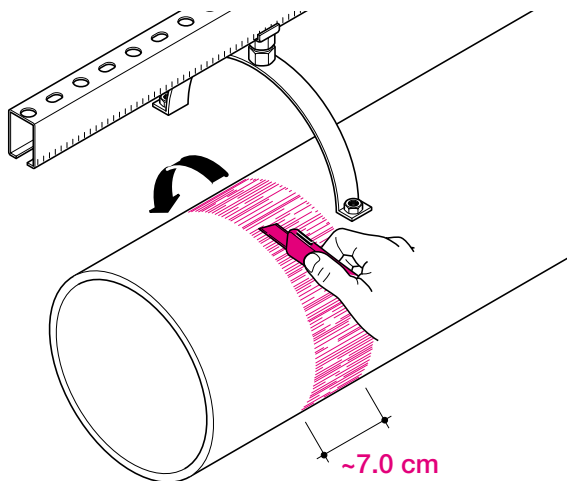

C4.

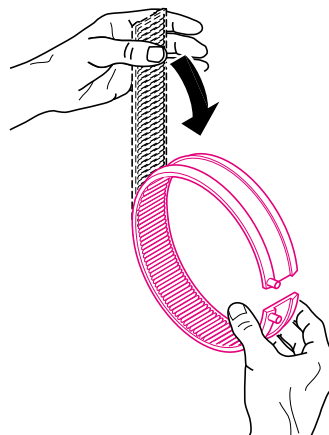

Geberit Montage 371.861

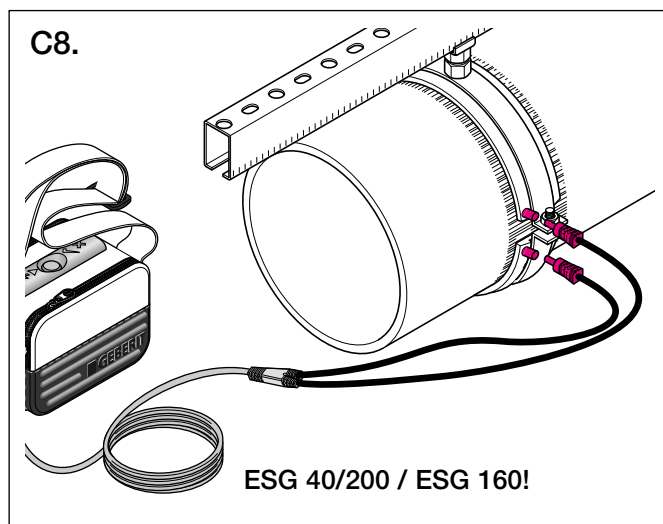
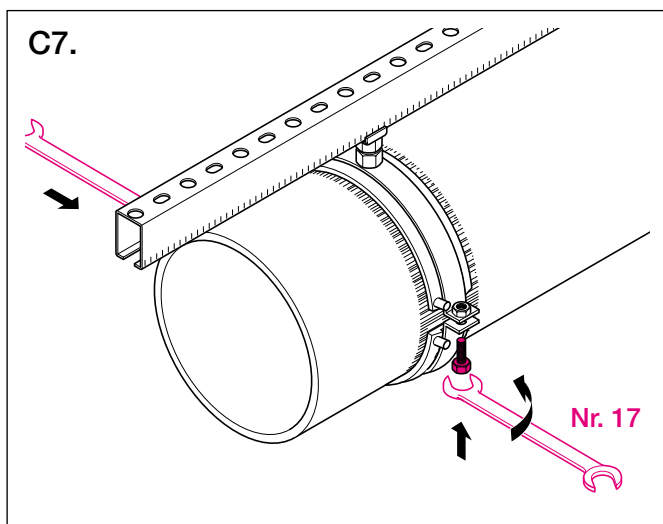
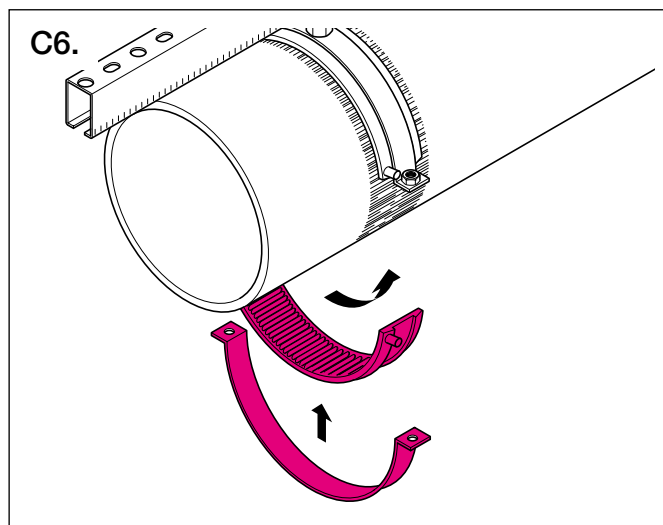
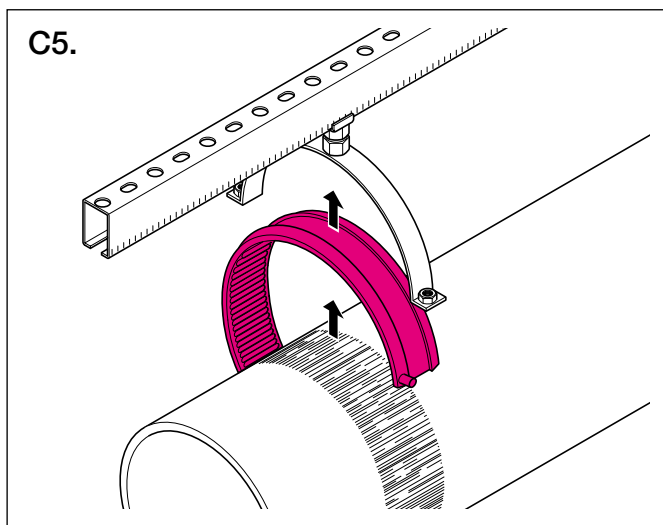

Achtung!

Darf nicht über Tragschalen geschweisst werden!
Elektroschweissband darf nur einmal verschweisst werden!

Attention!

Ne doit en aucun cas être soudée sur les gouttières!
La bande électrique ne doit jamais être soudée plus d'une fois!

Attenzione!

Non può essere saldato su canaline portanti!
Saldare la fascetta elettrica per punto fisso solamente una volta!

Attentie!

Mag niet over metalen draagschalen gelast worden!
Elektrolasband mag maar één keer gelast worden!

Caution!

Welding over a support shell (sheet metal) is prohibited!
Refer strictly from welding the same electrowelding tape twice!

Geberit Montage 371.861

C8.

