

Data Sheet Gebo G316
Kugelhahn aus Edelstahl / Stainless steel ball valve

Code 607

- Kugelhahn 3-teilig
- Voller Durchgang
- Mit Anschweißenden und Schließlasche
- Ausblassichere Spindel
- Feinguss Gehäuse
- Max. Druckstufe PN 63

- 3 Pc. Ball valve
- Full bore
- With butt weld ends and lock handle
- Blow-out proof stem
- Investment casting body
- Max. pressure stage PN 63

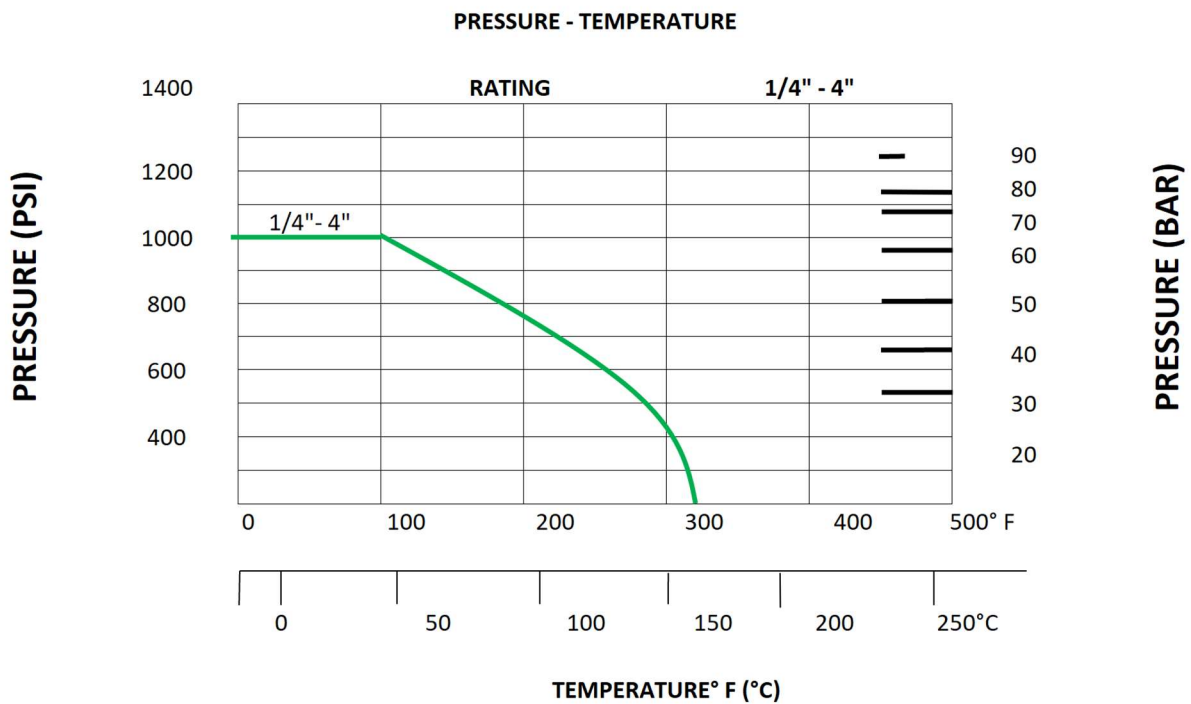

Data Sheet Gebo G316/Code 607
1/4" + "3/8" ISO-TOP

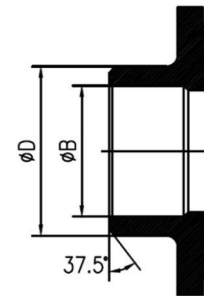
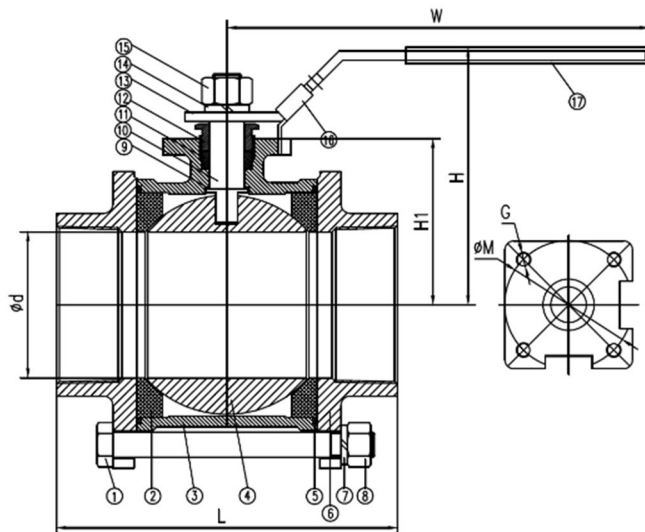

Butt Weld end

No.	Einzelteil	Part	qty	Material
1	Schraube	Bolt	4-6	AISI 304
2	Kugeldichtung	Ball seat	2	PTFE
3	Gehäuse	Body	1	ASTM - A351 - CF8M
4	Kugel	Ball	1	ASTM - A351 - CF8M
5	Dichtung	Joint gasket	2	PTFE
6	Abdeckung	Cap	2	ASTM - A351 - CF8M
7	Federscheibe	Spring washer	4-6	AISI 304
8	Sechskantschraube	Hex nut	4-6	AISI 304
9	Unterlegscheibe	Thrust washer	1	PTFE
10	Spindel	Stem	1	AISI 316
11	Spindeldichtung	Stem packing	1	PTFE
12	Buchse	Gland nut	1	AISI 304
13	Griff	Handle	1	AISI 304
14	Spindelscheibe	Stem washer	1	AISI 304
15	Spindelbuchse	Stem nut	1	AISI 304
16	Schließlasche	Lock device	1	AISI 304
17	Kunststoffabdeckung	Plastic cover	1	PLASTIC

Size	Art. No.	ø d	mm								kg
			L BW	H1	H	W	ISO 5211/ ØM	ISO 5211/G	B	D	
1/4"	607-014	11,6	59	27	51	95	36	M5	12	18	0,320
3/8"	607-038	12,7	59	27	51	95	36	M5	14	18	0,330

Data Sheet Gebo G316/Code 607
1/2" – 4" DIN 3202 M3

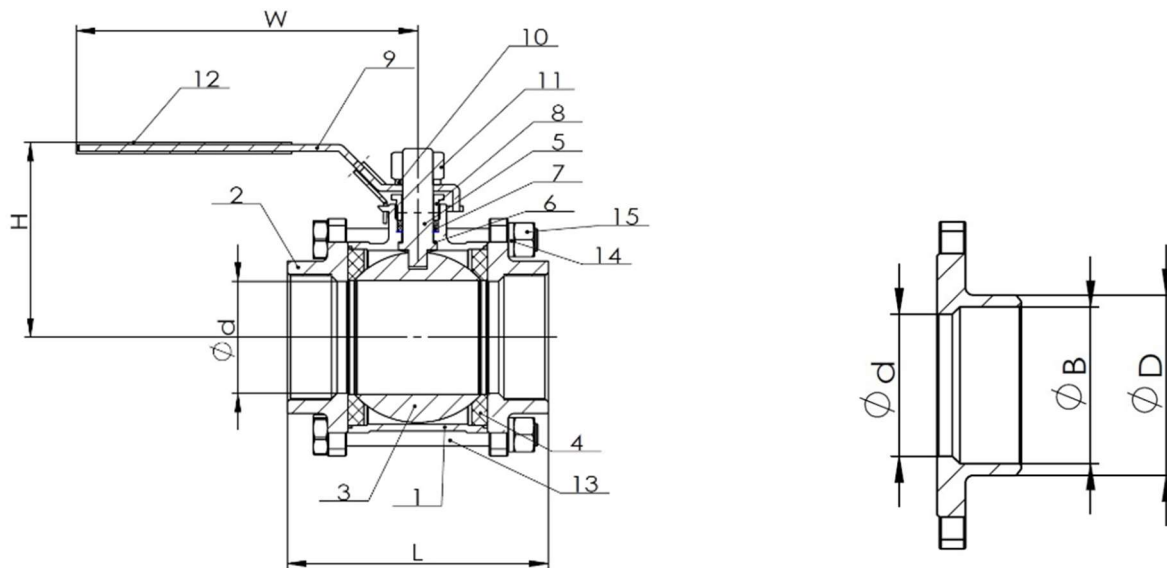

No	Einzelteil	PARTS	QTY	Material
1	Gehäuse	Body	1	ASTM - A351 - CF8M
2	Abdeckung	Cap	2	ASTM - A351 - CF8M
3	Kugel	Ball	1	ASTM - A351 - CF8M
4	Kugeldichtung	Ball seat	2	PTFE
5	Spindel	Stem	1	AISI 316
6	Unterlegscheibe	Thrust washer	1	PTFE
7	Spindeldichtung	Stem packing	2	PTFE
8	Buchse	Gland nut	1	AISI 304
9	Griff	Handle	1	AISI 304
10	Spindelscheibe	Stem washer	1	AISI 304
11	Spindelbuchse	Stem nut	1	AISI 304
12	Kunststoffabdeckung	Plastic cover	1	PLASTIC
13	Schraube	Bolt	6	AISI 304
14	Federscheibe	Spring washer	6	AISI 304
15	Sechskantschraube	Hex nut	6	AISI 304

Size	Art.No.	Ø d	L	H	W	B	D	kg
		mm						
1/2"	607-012	15,0	75,0	55,0	95,0	15,5	21,3	0,449
3/4"	607-034	20,0	80,0	59,0	110,0	21,1	26,9	0,635
1"	607-100	25,0	90,0	73,0	135,0	27,3	33,7	0,910
1 1/4"	607-114	32,0	110,0	78,0	135,0	35,2	42,4	1,505
1 1/2"	607-112	38,0	120,0	91,0	147,0	41,1	48,3	2,065
2"	607-200	50,0	140,0	99,0	165,0	52,3	60,3	3,150
2 1/2"	607-212	65,0	185,0	130,0	215,0	65,0	76,1	6,685
3"	607-300	80,0	205,0	142,0	215,0	80,0	88,9	9,790
4"	607-400	100,0	240,0	174,0	310,0	102,0	115,0	20,320